

德士凸輪股份有限公司
TE-SHIN CAM CO., LTD.

Rotary Table

ZERO-BACKLASH Roller Cam Table
Have 40 years professional
production technology

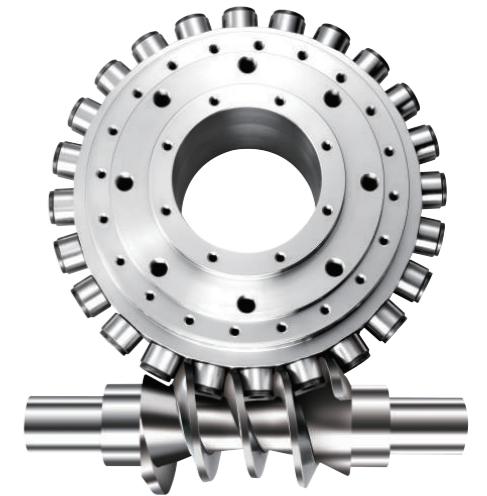

德士凸輪股份有限公司
TE-SHIN CAM CO., LTD.

No.88, Chajhuan 1st St., Gueishan Dist., Taoyuan City 333, Taiwan
TEL : 886-3-349-3596 FAX : 886-3-349-3600
E-mail : dex.cams@msa.hinet.net

昆山弘迪精密機械有限公司

DE SHIN PRECISION MACHINE CO., LTD.

No.3088, BeiMen Road, YuShan Town, Kunshan City, Jiangsu, China
TEL : 86-512-5519-3688 FAX : 86-512-5519-2688
E-mail : hongdi20051128@163.com

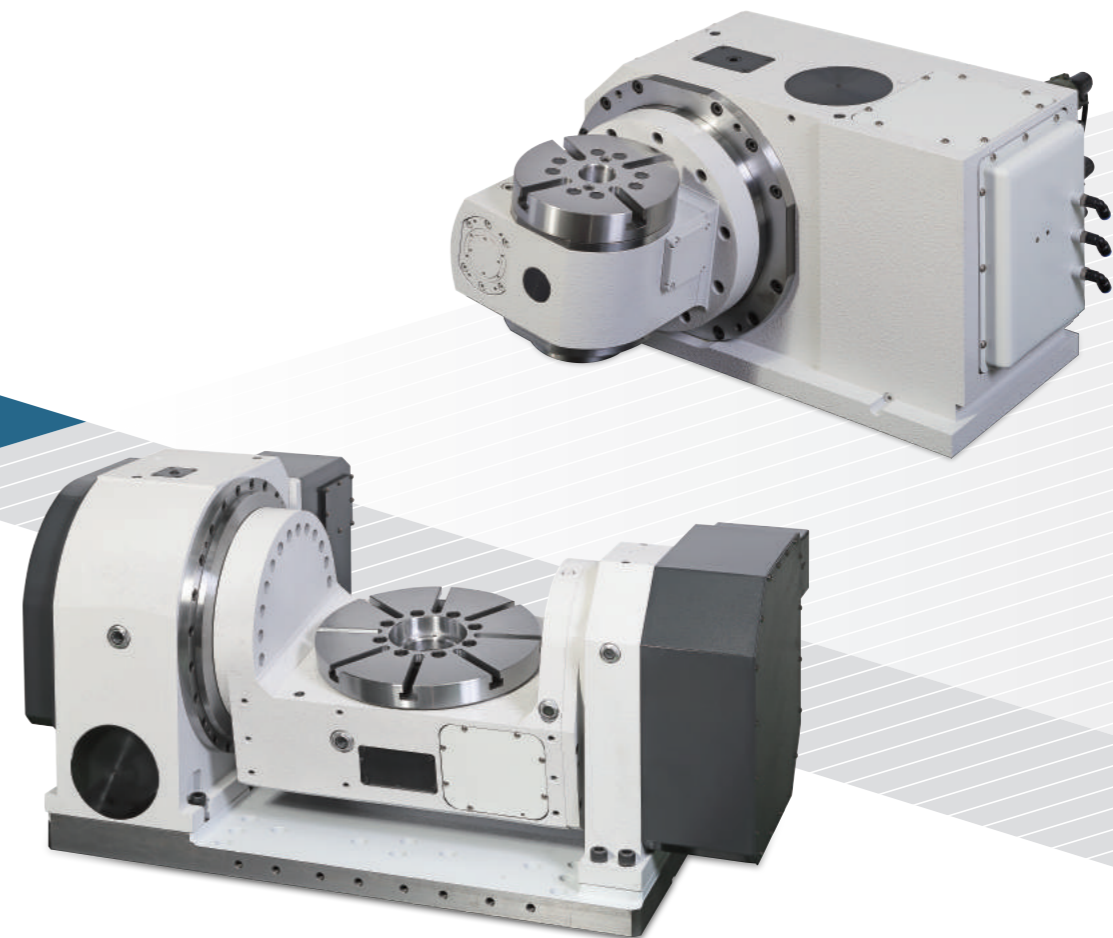

※ TE SHIN policy prohibits the above products from being used for the development or production use or stockpiling of weapons of mass destruction (nuclear weapons, biological weapons, chemical weapons or missiles).





德士凸輪股份有限公司

TE-SHIN CAM CO., LTD.

Strong Team --- High Quality --- Service



Brief

The Te-shin Cam Company was established in 1982 and commenced Cam Machining business in 1987. The company was engaged in the production/sales of ATC, Divider and Index Table in 1988 and 2010 respectively.

The Company has three factories to provide the on-line production which of the two were located at the Guishan district of Taoyuan, and another is at Kunshan city of Jiangsu, China. The plant area is up to 12,000 square meters and employed with 400 staffs. The company's capital is NT\$480,000,000.

The company has accumulated 40 years of rich practices of experience in machining design manufacture. Especially to meet the demand of customers' in the cam manufacturing and the ATC in the machine industry or the index divider in the automatic equipments. Which the company has won the high praise with affirmation in various fields and hold the 75% of usage in the existing market as well.

As known, an outstanding team has to be able to manufacture excellent product in quality since we have strict requirement in quality control and to meet the needs of satisfaction with customers after goods sales-service.

Presently we are promoting the precision of power turrets, regardless in the positioning accuracy, cutting power, steel structural or the lifetime in usage can be compared with the famous European/American/Japan brands. Especially to be assigned to use by some customers in Dutch and USA.



Milestones

1982 Dex Cams established : first to establish cam processing business.

1987 Starts producing and marketing **high speed roller ATC**.

1988 Expanding production and marketing **roller divider**.

2010 Continuing expanding production and marketing of **index table**.



All series

40 years of expertise
Subverting tradition.
Create world-class products

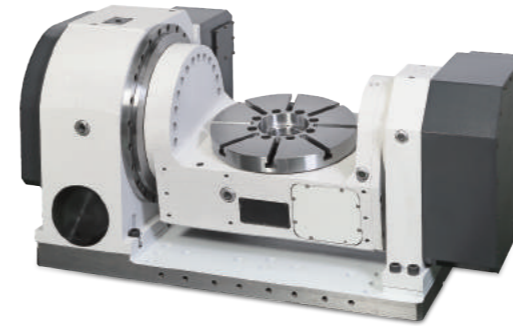

▲ 5 axis rotary table (AC400)

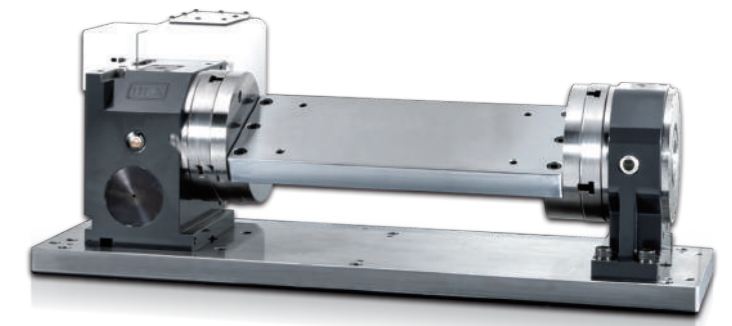

▲ Rotary table+Middle Plate+Tailstock

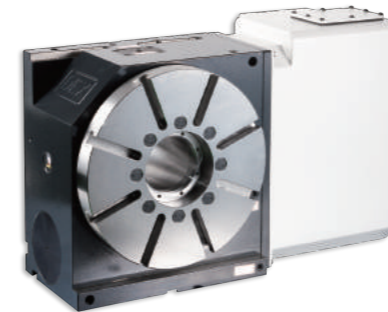

▲ RD320 Rotary Table

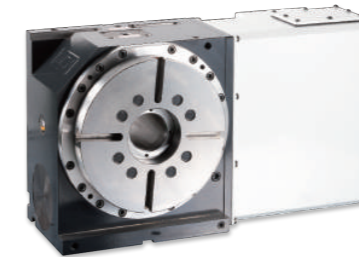

▲ RD250 Rotary Table

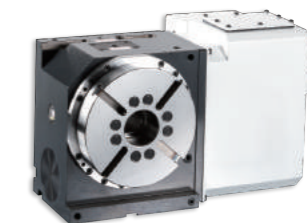

▲ RD200 Rotary Table



▲ RD170 Rotary Table



▲ Faceplate Tailstock 160



▲ Manual Tailstock 185



▲ BT 40 Vertical digital ATC tool changer



▲ CNC machine horizontal ATC tool changer



▲ AD Series precision index divider



▲ DF Series index divider

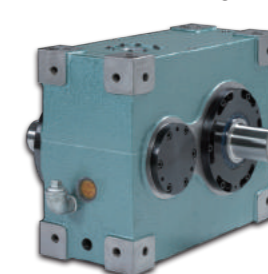

▲ P Series Parallel cam divider

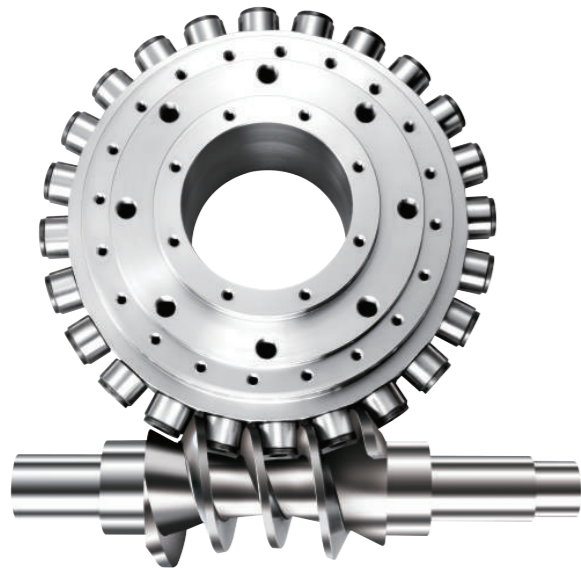

Rolling conduction
Conduction efficiency 90~95%

Roller cam drive

Features advantages:

- 1. Zero backlash:**
Rolling contact between the roller and the cam, no positive reversal backlash problem, greatly improving the ultra-precision characteristics of the roller cam, reducing the defect rate and improving the quality, which is a breakthrough for precision machining technology.
- 2. Ultra-high efficiency conduction:**
Roller cam type turret conducts in rolling mode, reduces wear, high transmission efficiency, high speed operation, and conduction efficiency of over 90%.
- 3. No thermal displacement:**
Even at high speeds, reduce friction, reduce thermal displacement, improve quality stability, and reduce non-performing rates.
- 4. Maintenance-free:**
Due to low wear and low aging, it can maintain initial accuracy for a long time.
- 5. Long life:**
Roller conduction method, can reduce wear and have long service life.
- 6. Braking performance:**
When the brake is positioned, the disc surface will not sway back and forth, and the positioning brake will remain within 2um, which can highly demonstrate the precision machining quality.



Friction extrusion
Conduction efficiency 50~60%

Worm & gear drive

1. Friction extrusion conduction, worm gear easy to wear and short life.
2. Conduction efficiency 50~60%
3. Accuracy reliability is not easy to maintain
4. For the high-precision machining, the reverse direction will produce backlash, which will affect the processing quality.
5. High-speed cutting is prone to process quality and thermal displacement.
6. Even if the optical scale is added, only the positioning accuracy can be solved, but when the backlash error is large, the vibration frequency during processing is high. (The surface roughness is poor), the optical ruler compensation compensates for the vibration frequency during processing and the wear of the tool is higher than roller cam type.

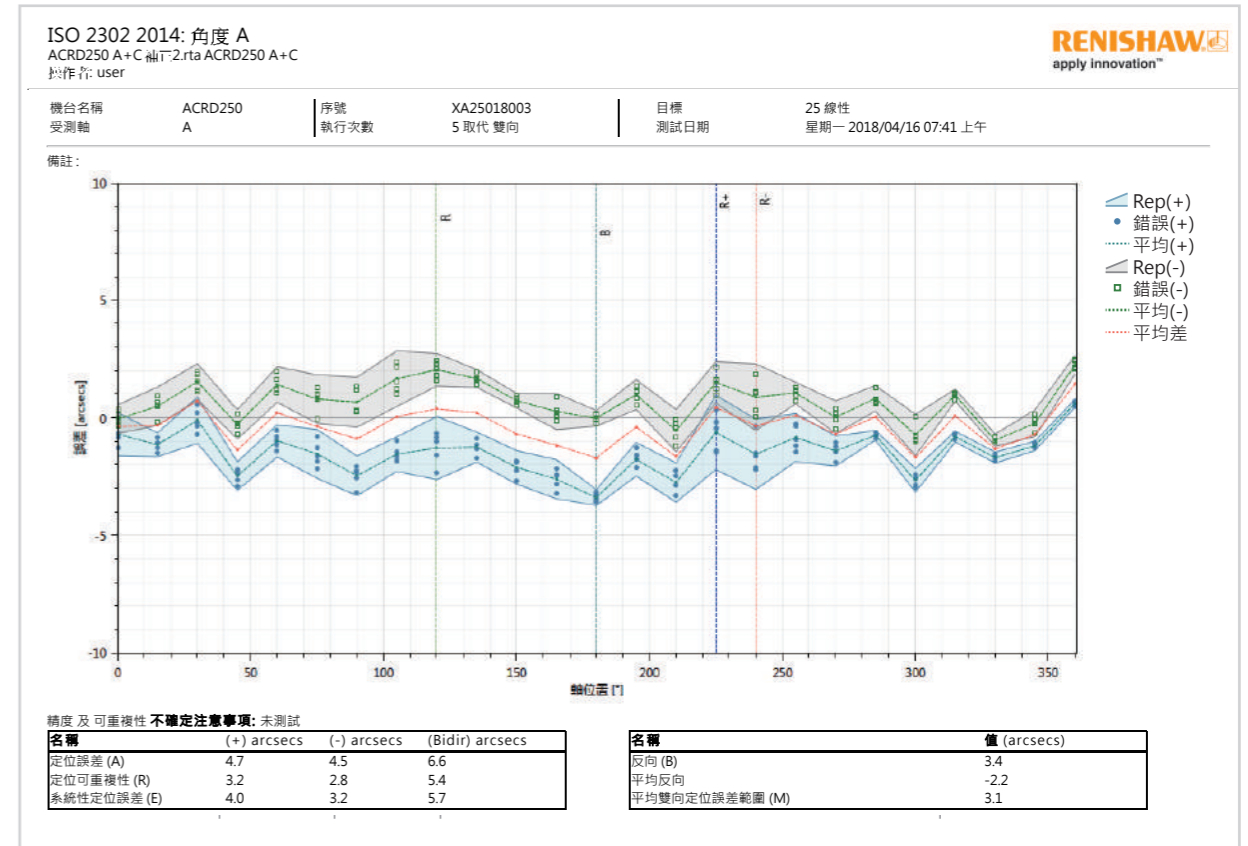



Roller cam rotary table (RD Series)

- Zero backlash
- Roller cam type turret conducts in rolling mode to reduces wear.
- Forward & reverse rotary are high accuracy and efficiency
- High rigidity
- Keeping high accuracy for long time
- Continuous processing for a long time, the accuracy is stable, there is no change the initial accuracy due to temperature rise



Item	TYPE	Unit	RDE80R		RDE170R		RD170R		RDS200R		RD200R		RDS250R		RD250R		RD320R		RD400R		
			α	□90	αiF4	□130	αiF4	□130	αiF4	□130	αiF4	□130	αiF8	□130	αiF8	□130	αiF12	□176	αiF12	□176	
Table Diameter		mm	80		170		170		200		200		250		250		320		400		
Center height		mm	80		135		135/160		160		160		160		185		210		255		
Center bore	Front spindle hole	mm	30H7		55H7		55H7		55H7		60H7		60H7		90H7		120H7		150H7		
	Through hole	mm	20H7		36H7		45H7		45H7		45H7		45H7		60H7		90H7		120H7		
T slot width		mm	N/A		12H7		12H7		12H7		12H7		12H7		12H7		14H7		14H7		
Guide block width		mm(h7)	14h7		14h7		14h7		14h7		18h7		18h7		18h7		18h7		18h7		
Servo Motor	FANUC	α	αiF2	□90	αiF4	□130	αiF4	□130	αiF4	□130	αiF4	□130	αiF8	□130	αiF8	□130	αiF12	□176	αiF12	□176	
		β	βiS2	□90	βiS8	□130	βiS8	□130	βiS8	□130	βiS8	□130	βiS8	□130	βiS8	□130	βis22	□176	βis22	□176	
	Mitsubishi	HF-75S	□90	HF-104T	□130	HF-104T	□130	HF-104T	□130	HF-104T	□130	HF-154T	□130	HF-154T	□130	HF-204S	□176	HF-204S	□176		
Motor interface	Siemens	N/A	N/A	1FK7060	□126	1FK7060	□126	1FK7060	□126	1FK7060	□126	1FK7063	□126	1FK7063	□126	1FK7083	□155	1FK7083	□155		
Gear ratio			1/24		1/36/45		1/36/45		1/36/45		1/60		1/50		1/60		1/72		1/120		
Table max.		r.p.m.	83		83		83		83		66		60		50		41		25		
Degree mini.		Degree	0.001		0.001		0.001		0.001		0.001		0.001		0.001		0.001		0.001		
Accuracy		Second	25		17		17		17		15		15		14		13		12		
Forward & Reverse repet.accuracy		Second	7		4		4		4		4		4		4		4		4		
Allowable cutting torque		[kgf-m]	[10]		[30]		[30]		[30]		[36]		[50]		[80]		[120]		[220]		
		N-m	98		294		294		294		352		490		784		1176		2156		
Clamp system		Pneumatic / Hydraulic	N / A		N / A		Pneumatic / Hydraulic		Pneumatic / Hydraulic		Pneumatic / Hydraulic		Pneumatic / Hydraulic		Pneumatic / Hydraulic		Hydraulic		Hydraulic		
Clamp output at brake		kg-cm ²	N / A		N / A		6 / 30		6 / 30		6 / 30		6 / 30		6 / 30		30		30		
Clamp output torque at brake		[kgf-m]	N / A		N / A		[13 / 60]		[13 / 60]		[13 / 60]		[13 / 60]		[20 / 93]		[225]		[420]		
		N-m	N / A		N / A		127 / 588		127 / 588		127 / 588		127 / 588		196 / 911		2205		4116		
Allowable work weight (Radial) Straight		kg	30		80		90		90		125		125		160		190		270		
Allowable work weight (Tailstock applied)		kg	60		160		180		180		250		250		300		370		540		
Allowable work weight (Axial) Flat		kg	60		160		180		180		250		250		300		370		540		
Allowable load (table clamped)		F	Kgf	N / A		N / A		1250		1250		2800		2800		3600		4600		8000	
			N	N / A		N / A		12250		12250		27440		27440		35280		45000		78400	
		FxL	Kgf-m	N / A		N / A		[13 / 60]		[13 / 60]		[13 / 60]		[13 / 60]		[20 / 93]		[225]		[420]	
			N-m	N / A		N / A		127/588		127/588		127/588		127/588		196/911		2205		4116	
	FxL	Kgf-m	N / A		N / A		45		45		125		125		130		300		650		
		N-m	N / A		N / A		441		441		1225		1225		1274		2940		6370		
Weight		kg	25		60		60		65		70		80		126		186		310		
Allowable inertia force		kg-m ²	0.2		0.6		0.6		0.6		1.2		1.5		2		4.5		10		

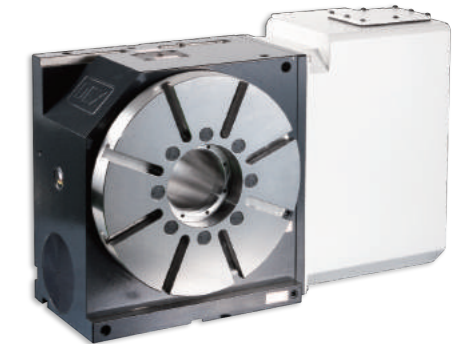

▲ RD320 Rotary table

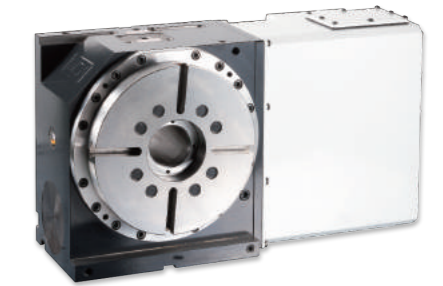

▲ RD250 Rotary table

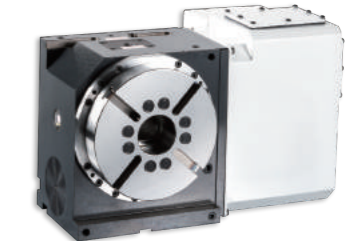

▲ RD200 Rotary table

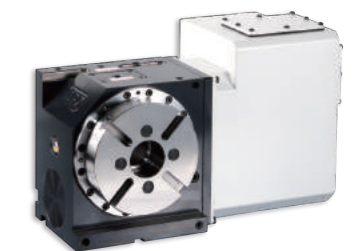

▲ RD170 Rotary table



▲ RDE80 Rotary table



Specification Unit : mm

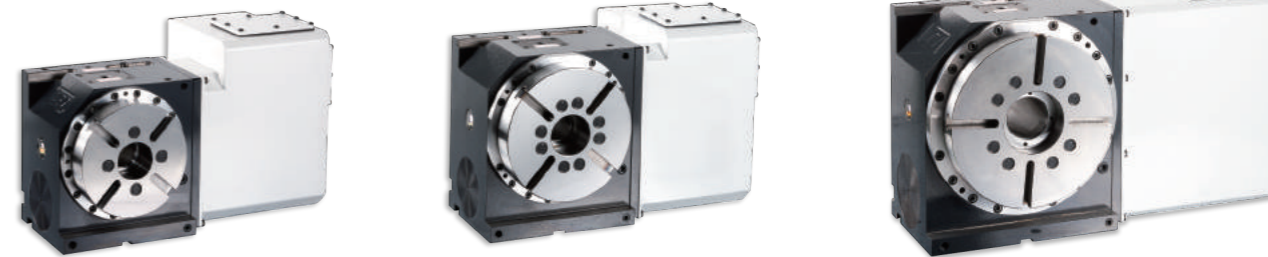
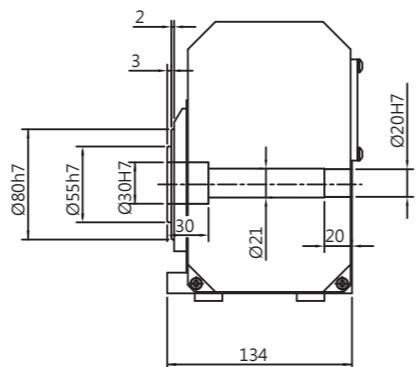
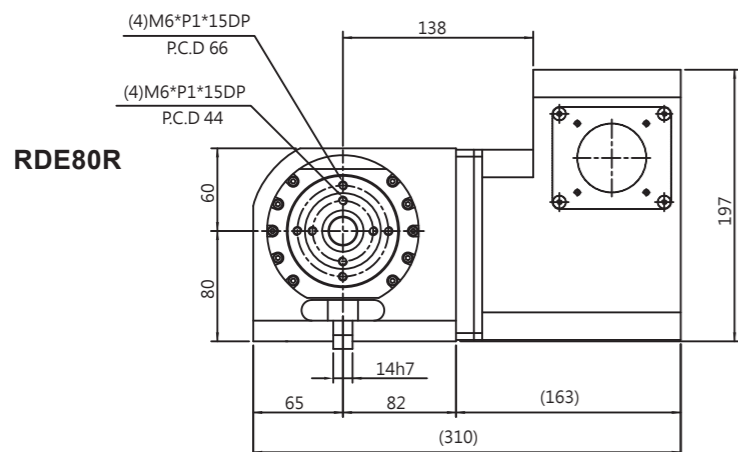
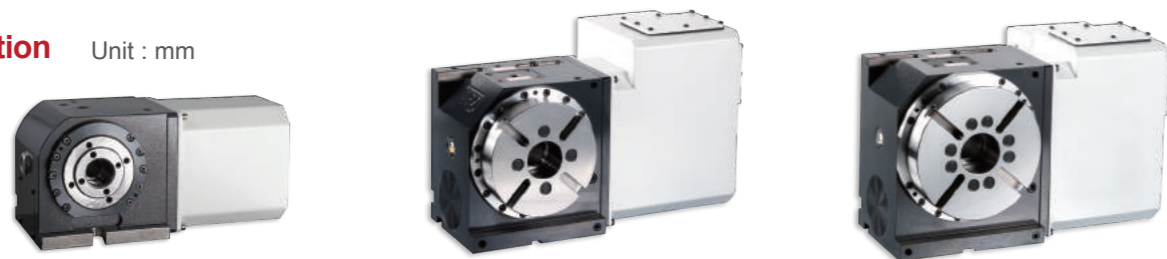

RDS200R

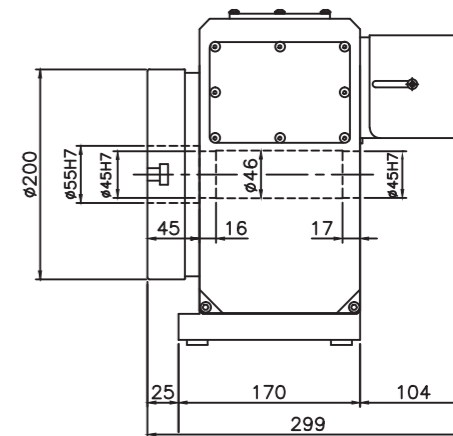
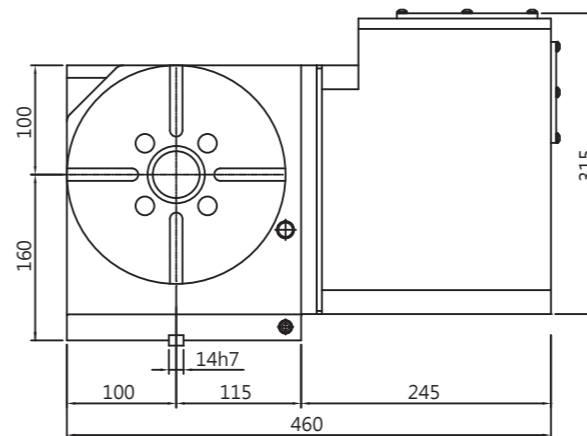

RDE170R

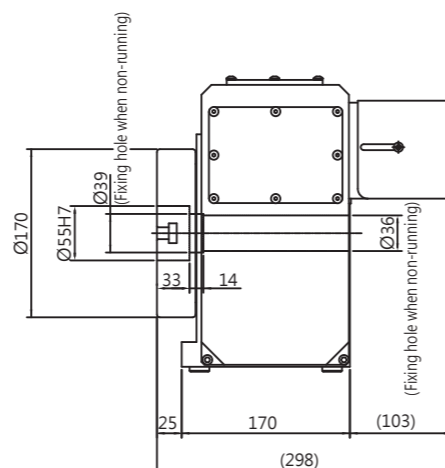
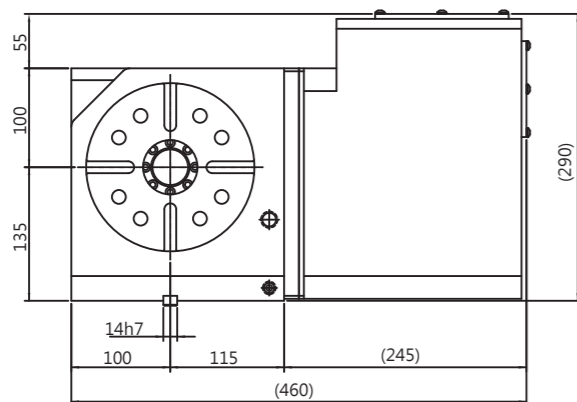

RD200R

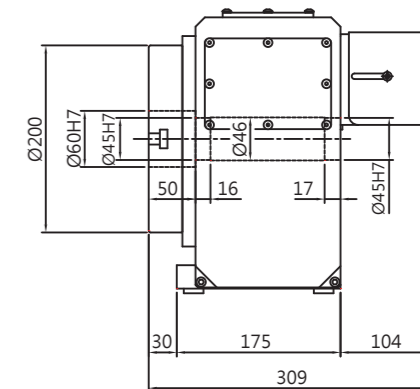
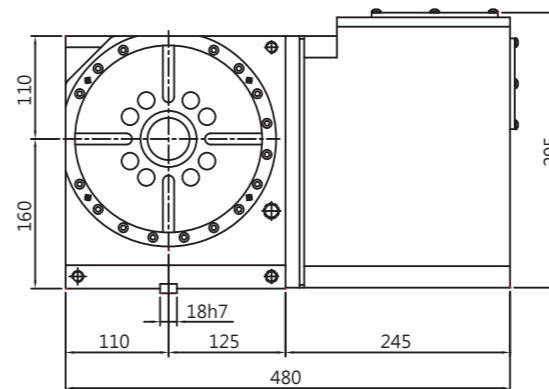

RD170R

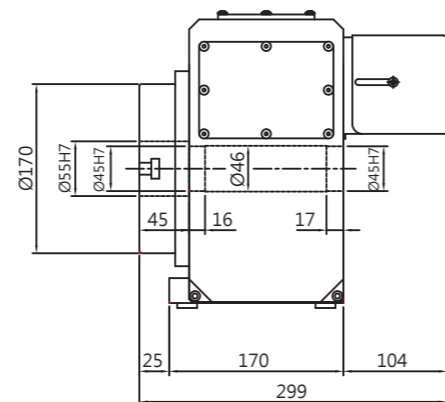
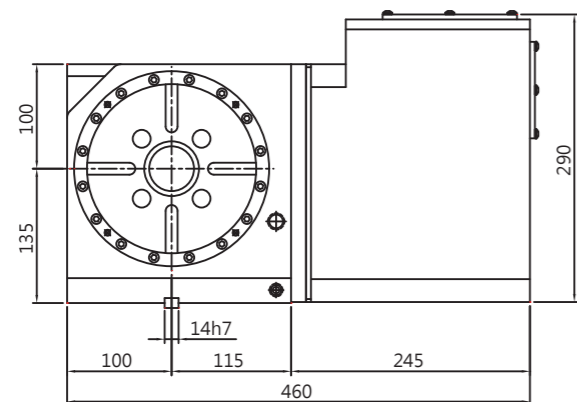

RDS250R

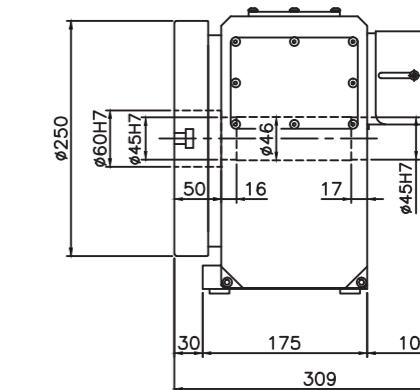
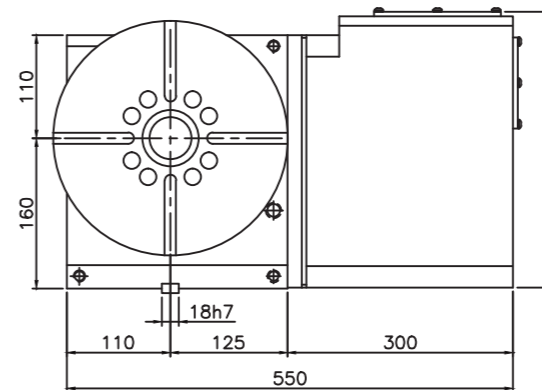

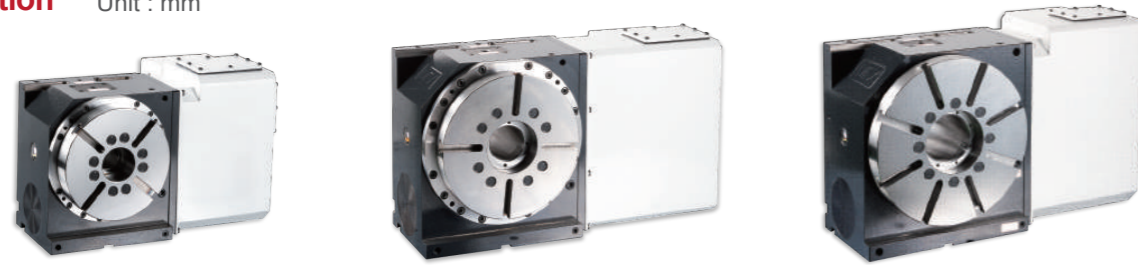

RD250R

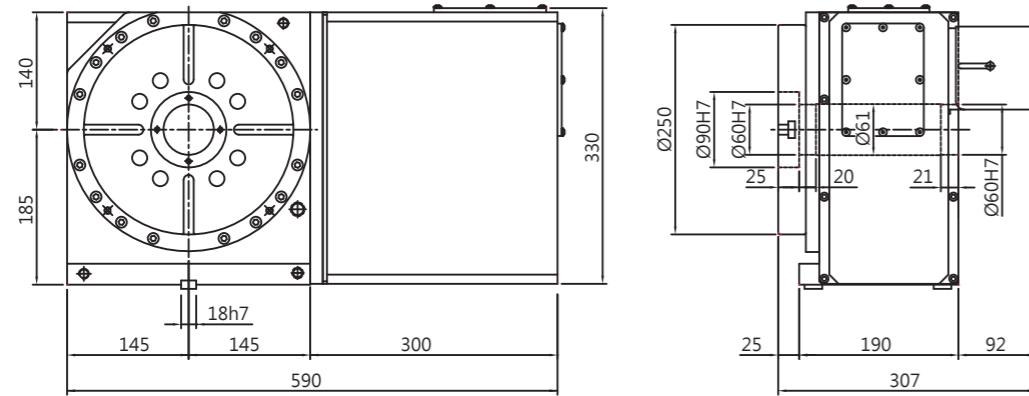

RD320R

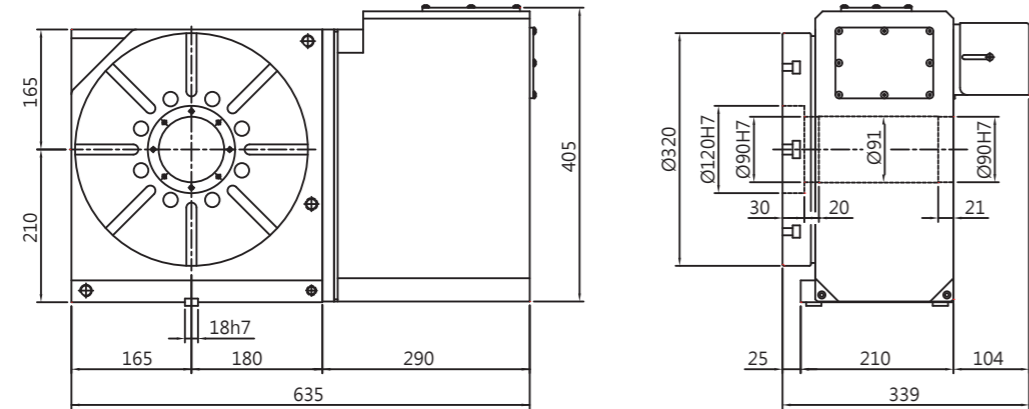

RD400R

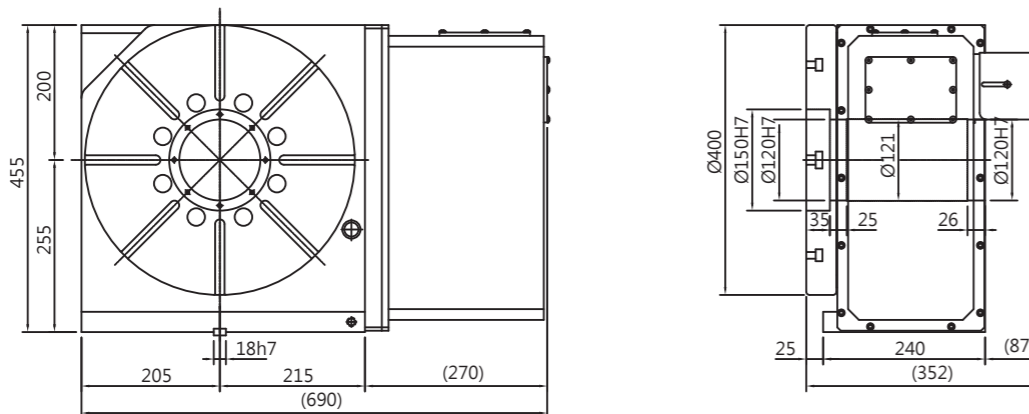

ACU150

Item	Unit	Specification
Table diameter	mm	Φ150
Table center Height	mm	255
Datum hole	mm	Φ35H7
Through-hole	mm	Φ25H7
T-slot on table	mm	12H7
Datum positioning key	mm	14h7
Allowable work-piece load	kg	40
Allowable cutting torque	kg-m	12
Axis	Degree	Rotating axis (C-axis), 360° Tilt axis (A-axis), -30° to +120°
Servo motor (Option)	FANUC	α iF2 Motor interface α iF4 Motor interface
		β iS2 □ 90 β iS8 □ 130
	Mitsubishi	HF-KP43 □ 60 HF-104 □ 130
	Siemens	1FK7034 □ 72 1FK7060 □ 126
Total reduction ratio		1/48 1/60
Maximum rpm	rpm	83 66
Clamp power source		Pneumatic Pneumatic
Clamp pressure	kg / cm ²	8 8
Clamp torque	kg-m	6 24
Index accuracy	sec	20 15 (-30°~+120°)
Repetition accuracy	sec	8 4
Product weight	kg	175

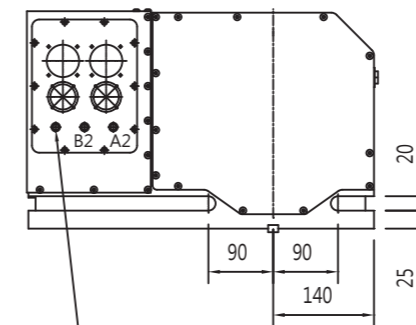
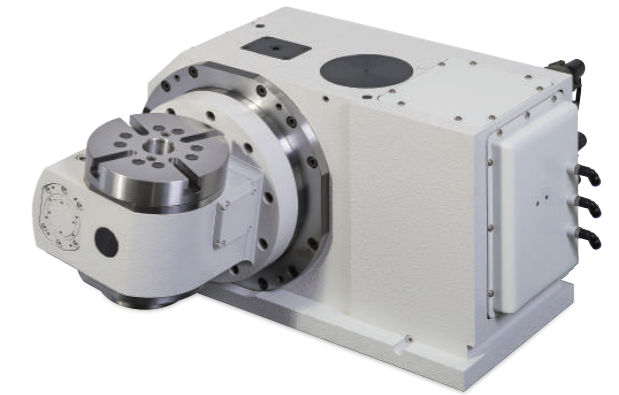

A, C-axis clamp source input

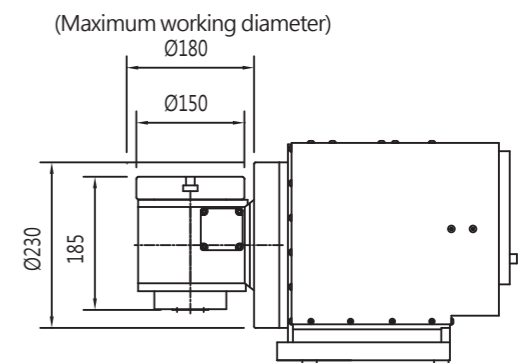
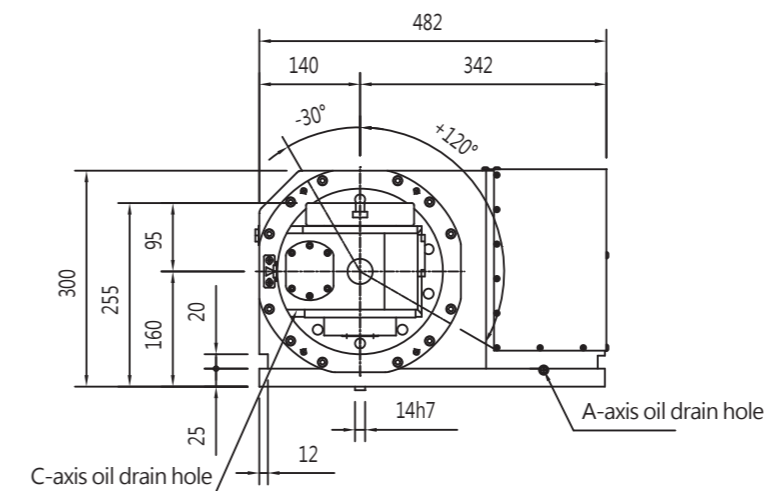
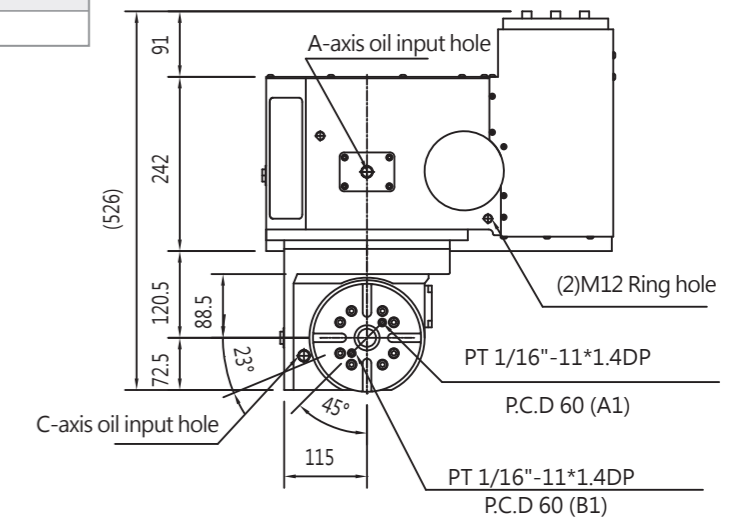

ACU200

Item	Unit	Specification	
Table diameter	mm	Φ200	
Table center Height	mm	230	
Datum hole	mm	Φ55H7	
Through-hole	mm	Φ45H7	
T-slot on table	mm	12H7	
Datum positioning key	mm	14h7	
Allowable work-piece load	kg	60	
Allowable cutting torque	kg-m	12	
Axis	Degree	Rotating axis (C-axis), 360°	Tilt axis (A-axis), -30° to +120°
Servo motor (Option)	FANUC	α iF2 Motor interface	α iF4 Motor interface
		β iS4 □ 90	β iS8 □ 130
	Mitsubishi	HF-KP73 □ 80	HF-104 □ 130
	Siemens	1FK7034 □ 72	1FK7060 □ 126
Total reduction ratio		1/45	1/60
Maximum rpm	rpm	83	66
Clamp power source		Pneumatic	Pneumatic
Clamp pressure	kg / cm ²	8	8
Clamp torque	kg-m	12	24
Index accuracy	sec	20	15 (-30°~+120°)
Repetition accuracy	sec	8	4
Product weight	kg	207	

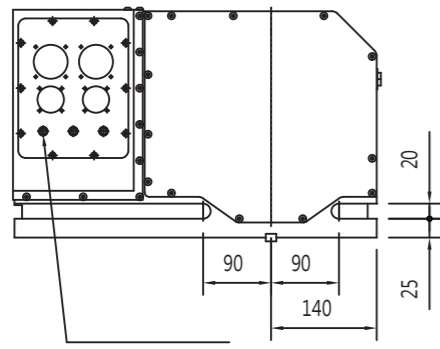
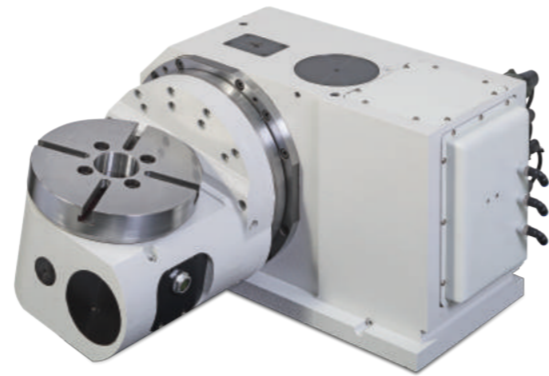

A, C-axis clamp source input

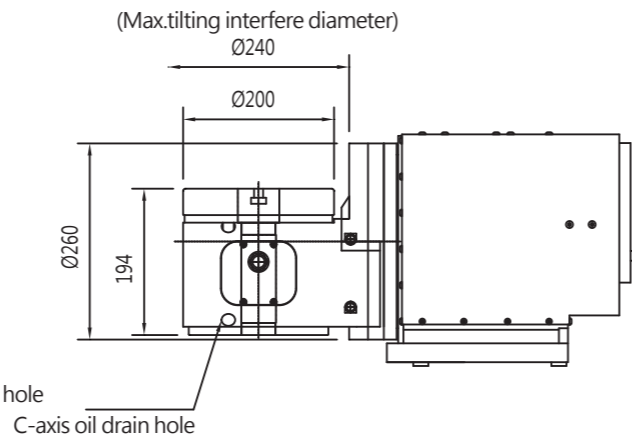
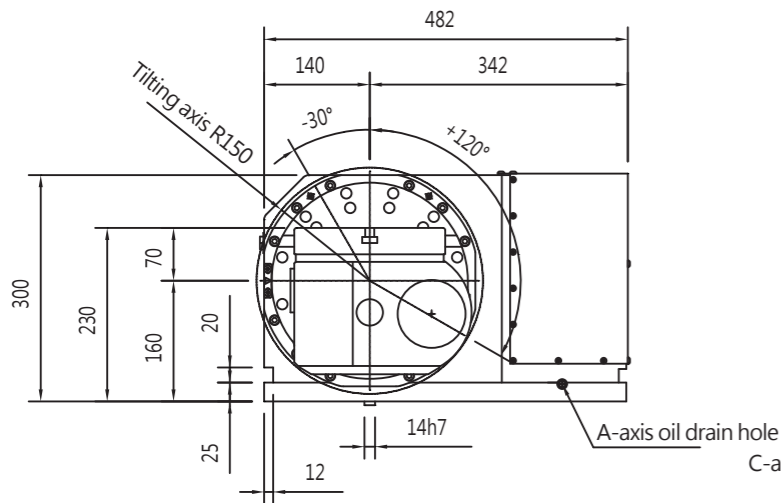
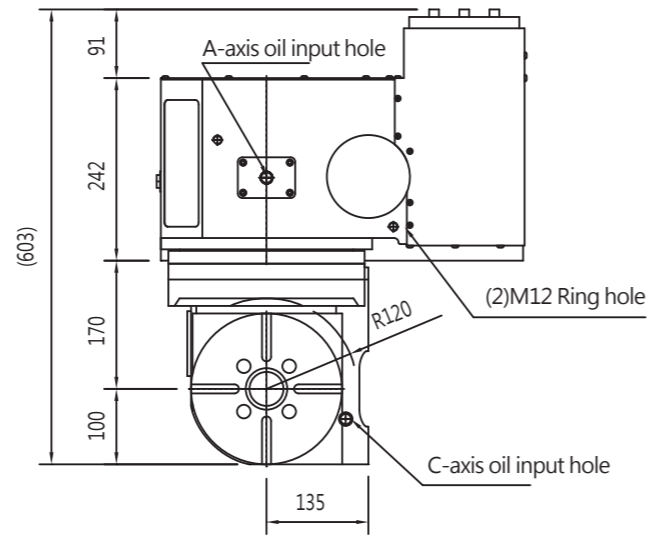

ACU250

Item	Unit	Specification	
Table diameter	mm	Φ250	
Table center Height	mm	315	
Datum hole	mm	Φ55H7	
Through-hole	mm	Φ45H7	
T-slot on table	mm	12H7	
Datum positioning key	mm	18h7	
Allowable cutting torque	kg-m	30	
Allowable work-piece load	kg	0°/ 120kg	90°/ 80kg
Axis	Degree	Rotating axis (C-axis), 360°	Tilt axis (A-axis), +30° to -110°
Servo motor (Option)	FANUC	α 4iF Motor interface	α 4iF Motor interface
		β 8iS □ 130	β 8iS □ 130
	Mitsubishi	HF-154S □ 130	HF-154S □ 130
	Siemens	1FK7060 □ 126	1FK7060 □ 126
Heidenhain	QSY116C □ 116	QSY116C □ 116	
Total reduction ratio		1/45	1/96
Mini. degree	Degree	0.001	0.001
Maximum rpm	rpm	44.4(200rpm)	20.8(200rpm)
Clamp power source		Pneumatic	Pneumatic
Clamp pressure	kg / cm ²	6	6
Clamp torque	kg-m	20	45
Index accuracy	sec	20	15 (+30°~-110°)
Repetition accuracy	sec	4	4

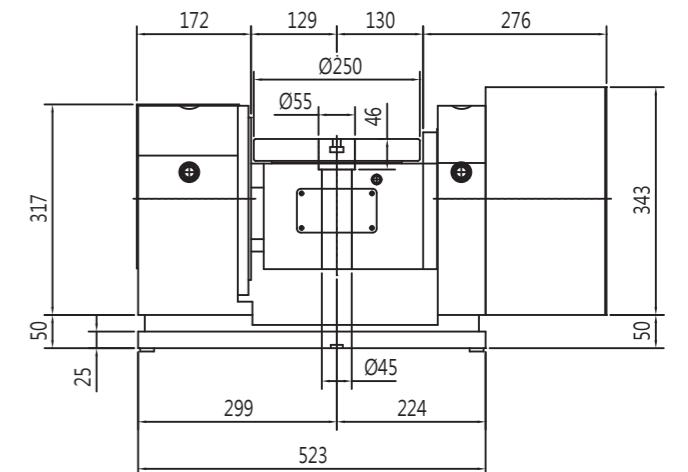
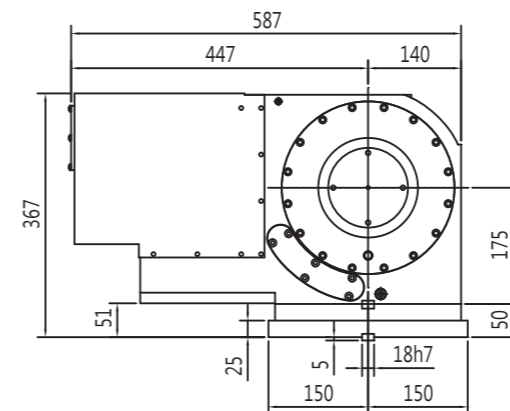
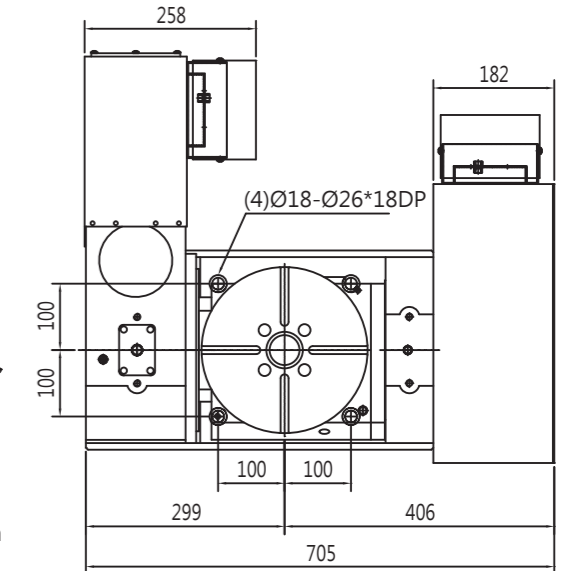
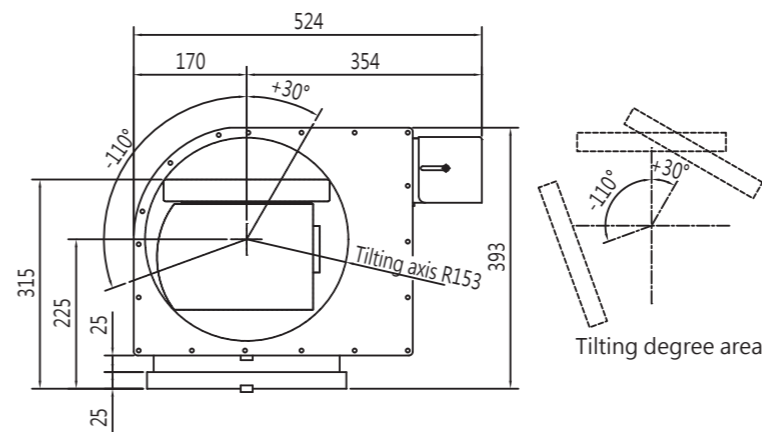

AC250

Item	Unit	Specification	
Workpiece dia.max.	mm	Φ335	
Table diameter	mm	Φ250	
Table center Height	mm	295	
Datum hole	mm	Φ90H7	
Through-hole	mm	Φ60H7	
T-slot on table	mm	12H7	
Datum positioning key	mm	18h7	
Allowable cutting torque	kg-m	50	
Allowable work-piece load	kg	0°/ 170kg	90°/ 140kg
Axis	Degree	Rotating axis (C-axis), 360°	Tilt axis (A-axis), +30° to -120°
Servo motor (Option)	FANUC	α 4iF	α 8iF+B
		β 8iS	β 8iS+B
	Mitsubishi	HF-154S	HF-154BS
	Siemens	1FK7060	1FK7063+B
Heidenhain	QSY116C	QSY116J+B	
Total reduction ratio		1/60	1/120
Mini. degree	Degree	0.001	0.001
Maximum rpm	rpm	50	25
Clamp power source		Hydraulic	Hydraulic
Clamp pressure	kg / cm ²	25	25
Clamp torque	kg-m	60	180
Index accuracy	sec	15	20 (+30°~-120°)
(with Encoder)		5	5 (+30°~-120°)
Repetition accuracy	sec	4	4
Encoder(Optional)	Heidenhain	RCN2000 (±2.5")	RCN2000 (±2.5")
Product weight	kg	480	

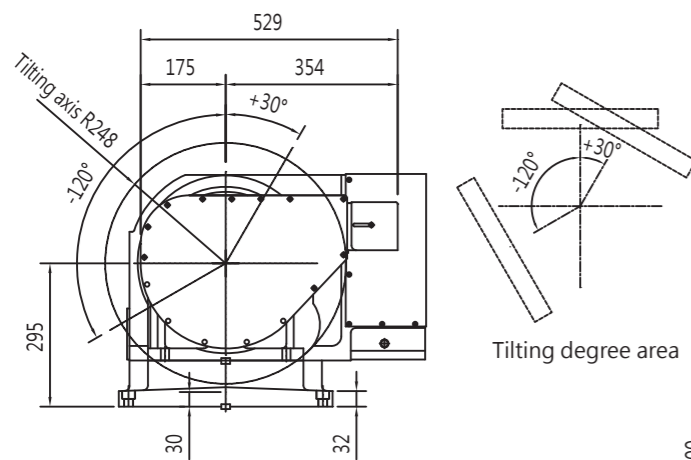
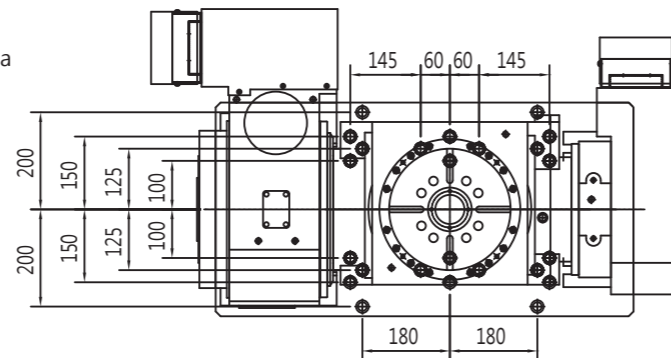
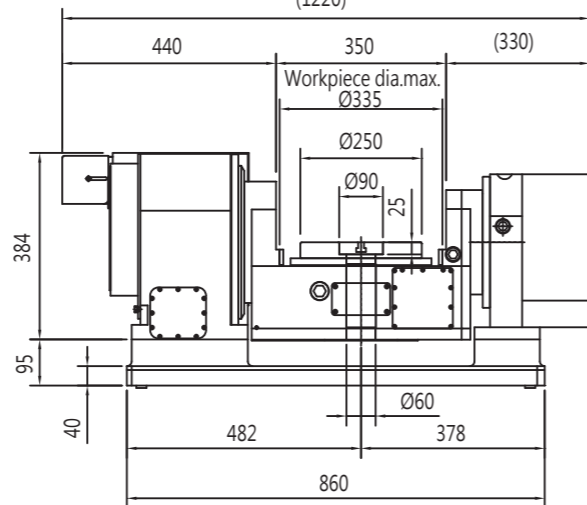
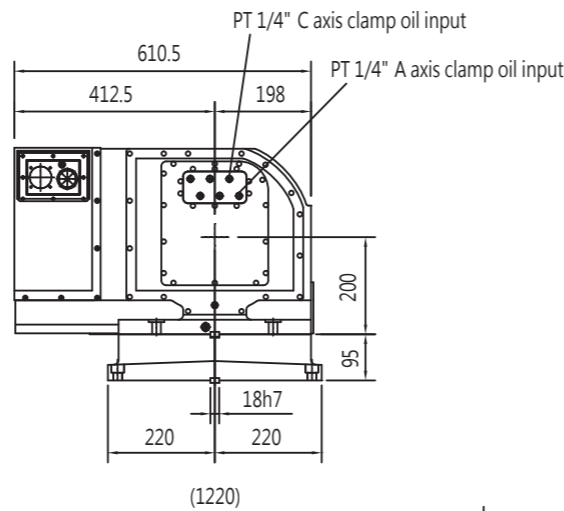
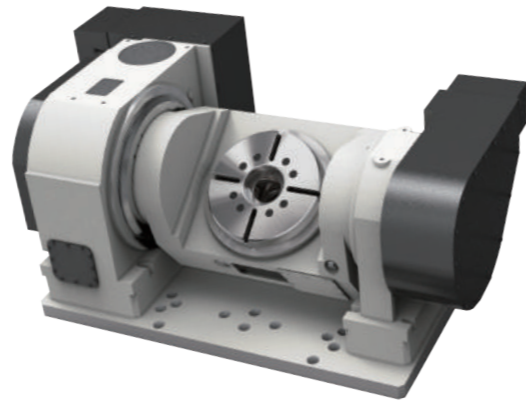

AC320

Item	Unit	Specification	
Workpiece dia.max.	mm	Φ440	
Table diameter	mm	Φ320	
Table center Height	mm	305	
Datum hole	mm	Φ90H7	
Through-hole	mm	Φ60H7	
T-slot on table	mm	14H7	
Datum positioning key	mm	18h7	
Allowable cutting torque	kg-m	81	
Allowable work-piece load	kg	0°/ 220kg	90°/ 170kg
Axis	Degree	Rotating axis (C-axis), 360°	Tilt axis (A-axis), +30° to -120°
Servo motor (Option)	FANUC	α iF8	α iF8+B
		β iS8	β iS8+B
	Mitsubishi	HF-154S	HF-154BS
	Siemens	1FK7063	1FK7063+B
Heidenhain	QSY116J	QSY116J+B	
Total reduction ratio		1/60	1/120
Mini. degree	Degree	0.001	0.001
Maximum rpm	rpm	50	25
Clamp power source		Hydraulic	Hydraulic
Clamp pressure	kg / cm ²	25	25
Clamp torque	kg-m	60	180
Index accuracy	sec	15	20 (+30°~-120°)
(with Encoder)		5	5 (+30°~-120°)
Repetition accuracy	sec	4	4
Encoder(Optional)	Heidenhain	RCN2000 (±2.5")	RCN2000 (±2.5")
Product weight	kg	540	

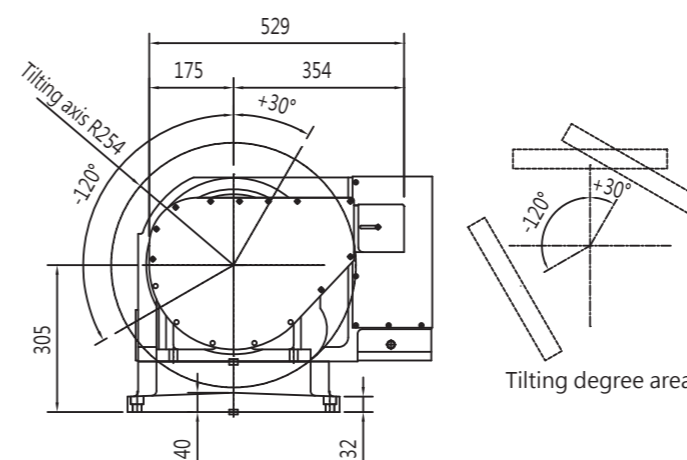
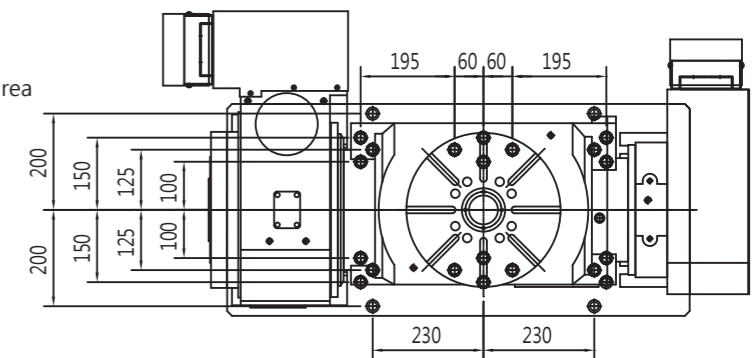
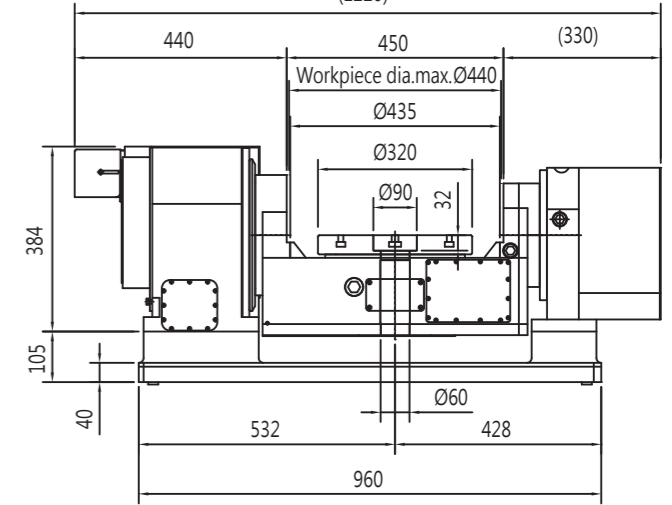
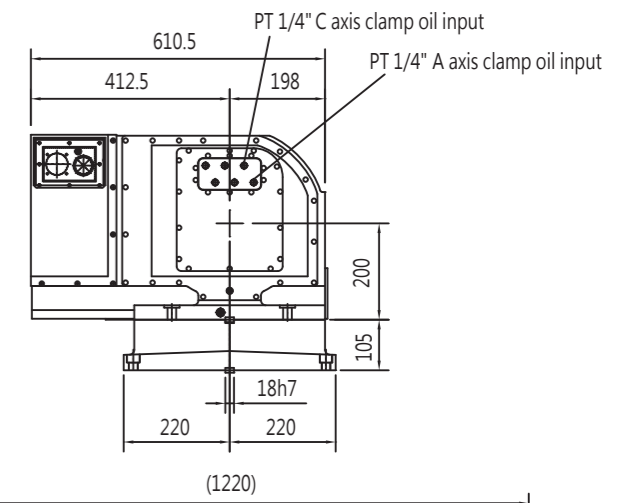
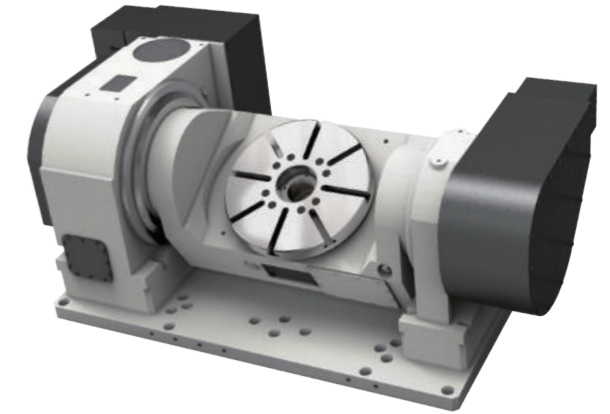

AC400

Item	Unit	Specification	
Workpiece dia.max.	mm	Φ430	
Table diameter	mm	Φ400	
Table center Height	mm	345	
Datum hole	mm	Φ120H7	
Through-hole	mm	Φ90H7	
T-slot on table	mm	14H7	
Datum positioning key	mm	18h7	
Allowable cutting torque	kg-m	91	
Allowable work-piece load	kg	0°/ 260kg	90°/ 200kg
Axis	Degree	Rotating axis (C-axis), 360°	Tilt axis (A-axis), +30° to -120°
Servo motor (Option)	FANUC	α iF8	α iF12+B
		β iS12	β iS22+B
	Mitsubishi	HF-154S	HF-204BS
	Siemens	1FK7063	1FK7083+B
	Heidenhain	QSY116J	QSY155C+B
Total reduction ratio		1/80	1/120
Mini. degree	Degree	0.001	0.001
Maximum rpm	rpm	37	25
Clamp power source		Hydraulic	Hydraulic
Clamp pressure	kg / cm ²	35	35
Clamp torque	kg-m	220	710
Index accuracy	sec	15	20 (+30°~-120°)
		(with Encoder)	5 (+30°~-120°)
Repetition accuracy	sec	4	4
Encoder(Optional)	Heidenhain	RCN2000 (±2.5")	RCN2000 (±2.5")
Product weight	kg	640	

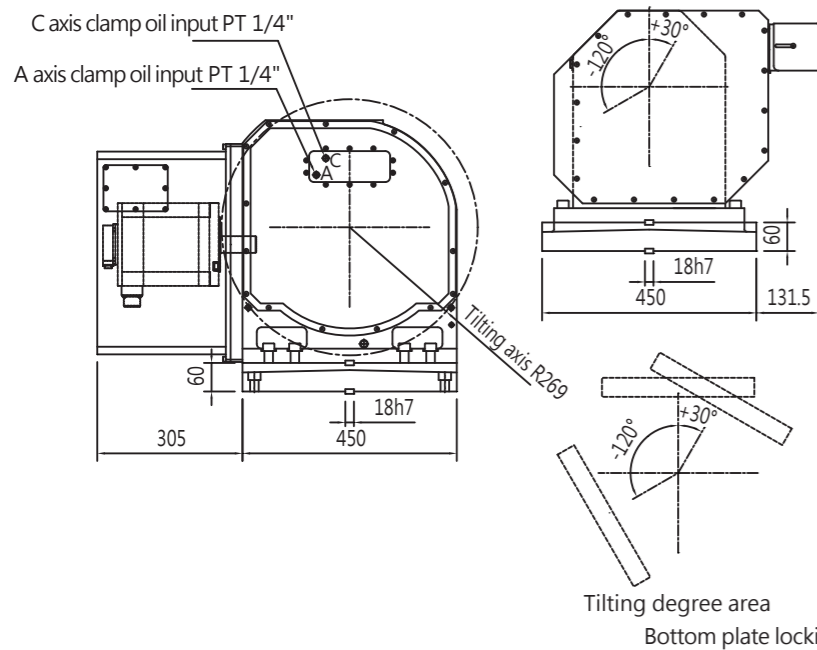
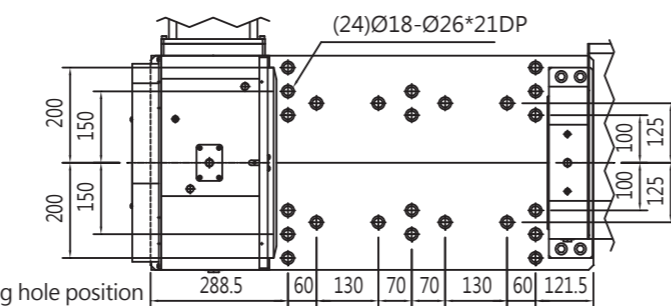
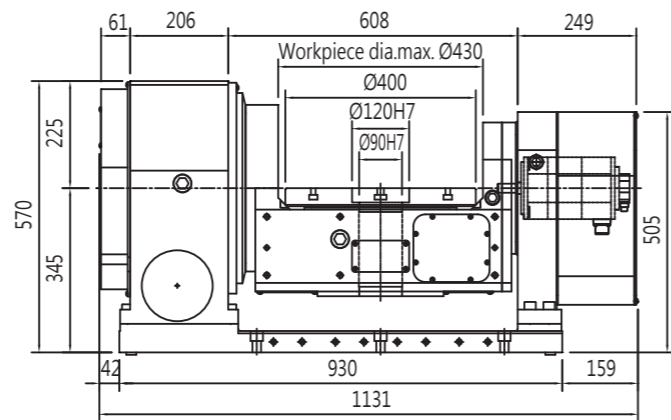
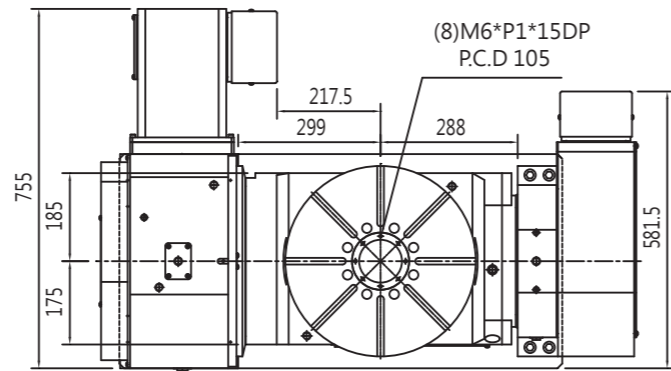
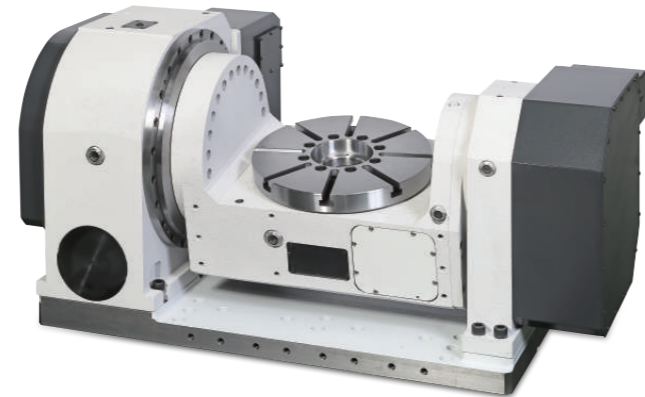

AC500

Item	Unit	Specification	
Workpiece dia.max.	mm	Φ660	
Table diameter	mm	Φ500	
Table center Height	mm	415	
Datum hole	mm	Φ150H7	
Through-hole	mm	Φ120H7	
T-slot on table	mm	18H7	
Datum positioning key	mm	18h7	
Allowable cutting torque	kg-m	195	
Allowable work-piece load	kg	0°/ 500kg	90°/ 340kg
Axis	Degree	Rotating axis (C-axis), 360°	Tilt axis (A-axis), +30° to -120°
Servo motor (Option)	FANUC	α iF8	α iF22+B
		β iS12	β iS22+B
	Mitsubishi	HF-154S	HF354BS
	Siemens	1FK7063	1FK7101+B
	Heidenhain	QSY130C	QSY190C+B
Total reduction ratio		1/96	1/120
Mini. degree	Degree	0.001	0.001
Maximum rpm	rpm	31	25
Clamp power source		Hydraulic	Hydraulic
Clamp pressure	kg / cm ²	35	35
Clamp torque	kg-m	250	710
Index accuracy	sec	15	20 (+30°~-120°)
		(with Encoder)	5 (+30°~-120°)
Repetition accuracy	sec	4	4
Encoder(Optional)	Heidenhain	RCN2000 (±2.5")	RCN2000 (±2.5")

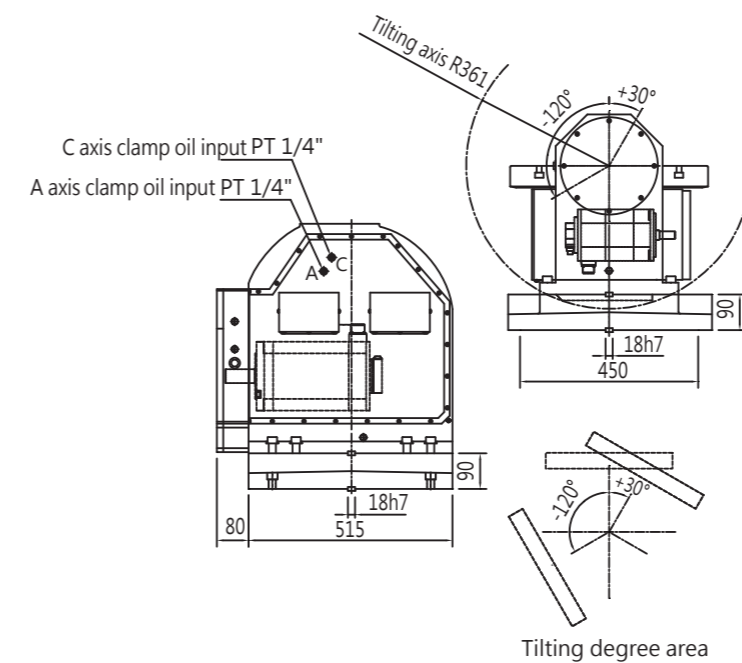
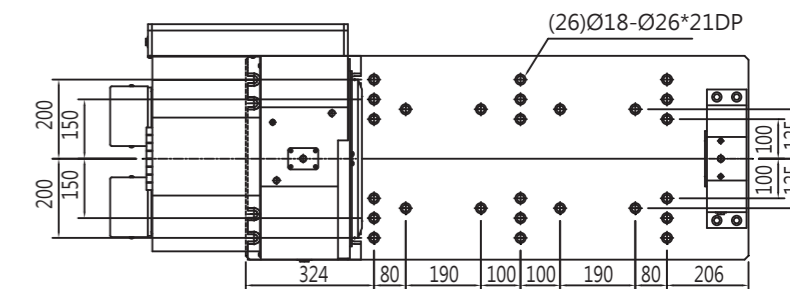
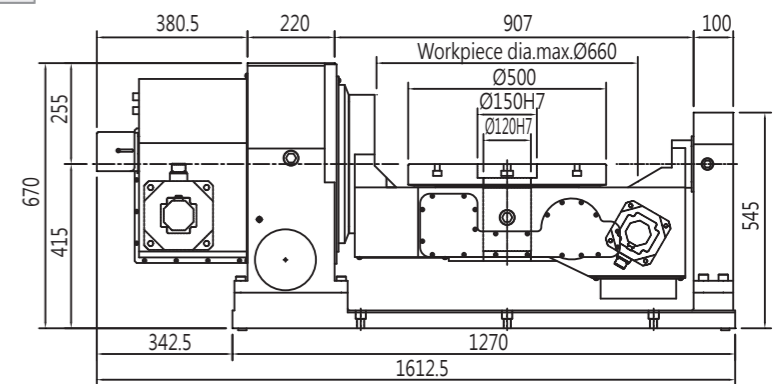
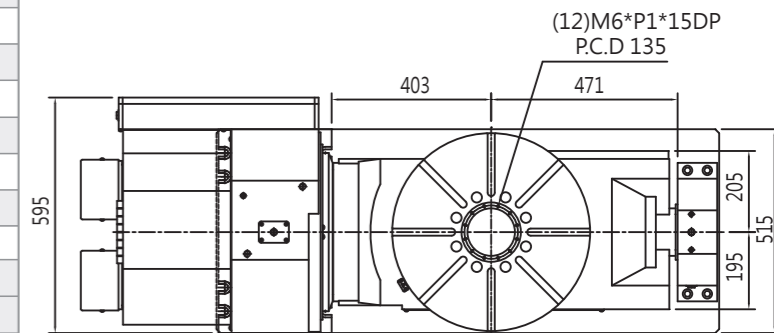
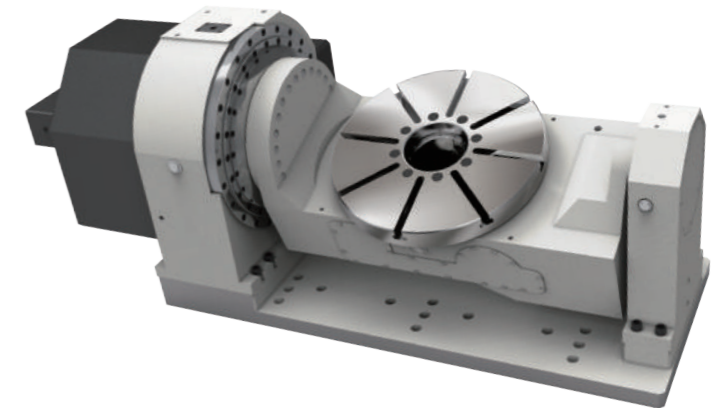

ACL650

Item		Specification	
Table diameter		Φ650mm	
Table center Height		760mm	
Table total height		-50mm	
Total length		1867.5mm	
Datum hole		Ø55H7 x 12 mm/Deep	
T-slot on table		18H7mm	
Axis		Rotating axis	Tilt axis
Servo motor (Option)	FANUC	a12iF	a40i+Fan
	Mitsubishi	HF204S	HF703S
	Siemens	1FK7083	1FK7105
	Heidenhain	QSY155C	QSY190D
Total reduction ratio		1 : 60	1 : 120
Maximum rpm		25(1500rpm)	25(3000rpm)
Index accuracy		15	45 (±120°)
Encoder		5	5 (±120°)
Repetition accuracy		4	4
Tilting degree without fixture & workpiece		+120° ~ -120°	
Clamp torque	□ Pneumatic(6kg/cm ²)		
	□ Hydraulic(40kg/cm ²)	262	458
Encoder(Option)	□ RCN2590 (±2.5")	(Option)	
Suitable work temp.		18°C ~ 40°C	
Allowable load	Level(0-45°)	300kg	
	Tilting(60-90°)	200kg	
Product weight		1200kg	

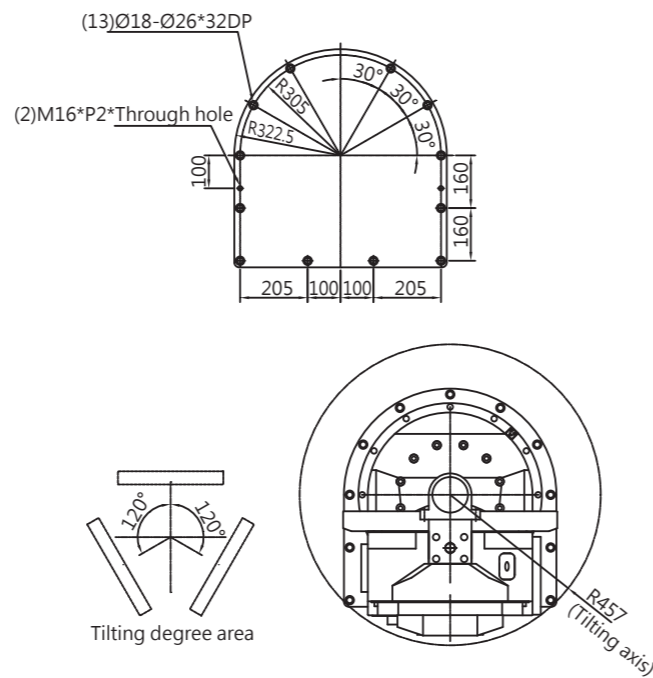
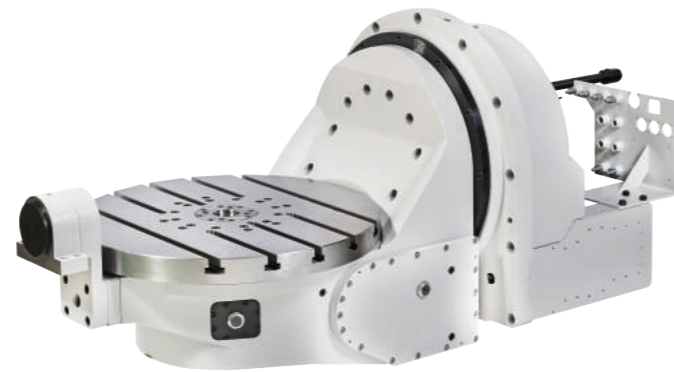

※ ACL650 High rigidity, high accuracy, long life (option type), please contact us.

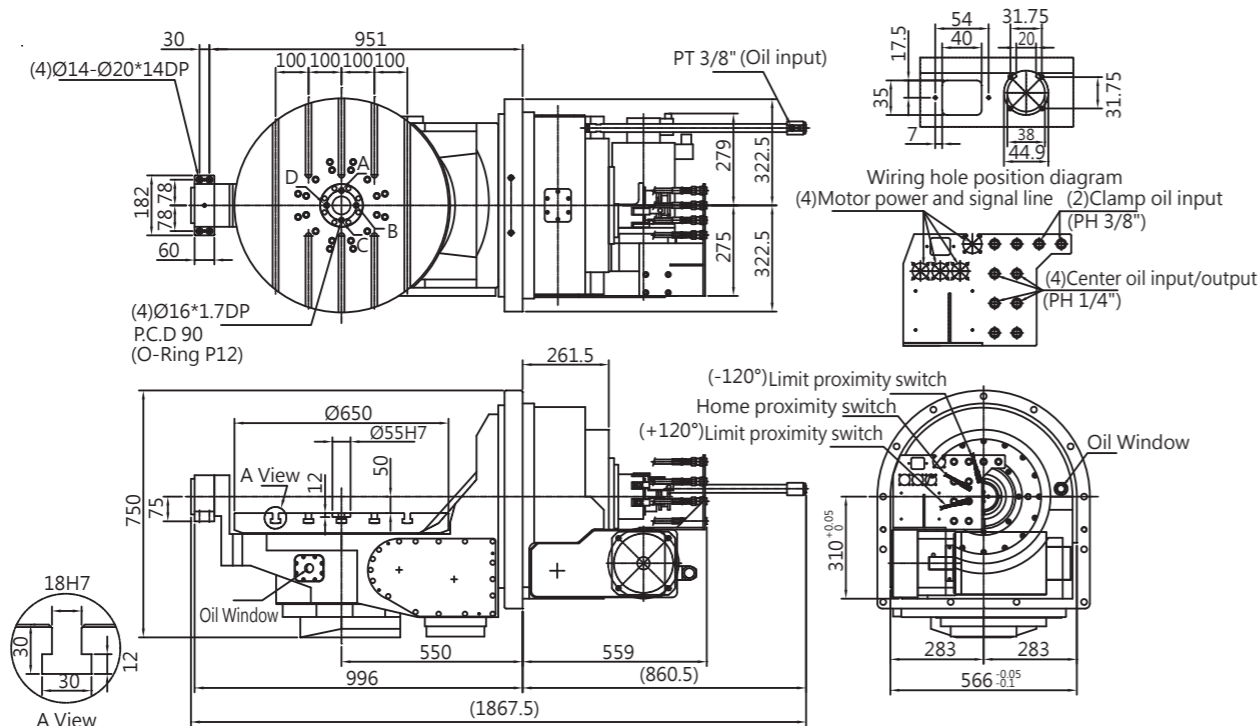

HRD450

Item	Unit	Specification	
Table diameter	mm	□ 450	
T-slot on table	mm	18H7	
Servo motor (Option)	FANUC	α iF12	Motor interface □ 176
		β is22	
	Mitsubishi	HF-204S	□ 155
		Siemens	
Heidenhain	QSY155B		
Total reduction ratio		96	
Maximum rpm	rpm	20.8(2000rpm)	
Index accuracy mini.	deg	0.001°	
Allowable load	kg	600kg	
Clamp power source		Hydraulic	
Clamp pressure	kg / cm ²	20	
Clamp torque	kg-m	400	
Index accuracy	sec	13	
Repetition accuracy	sec	4	

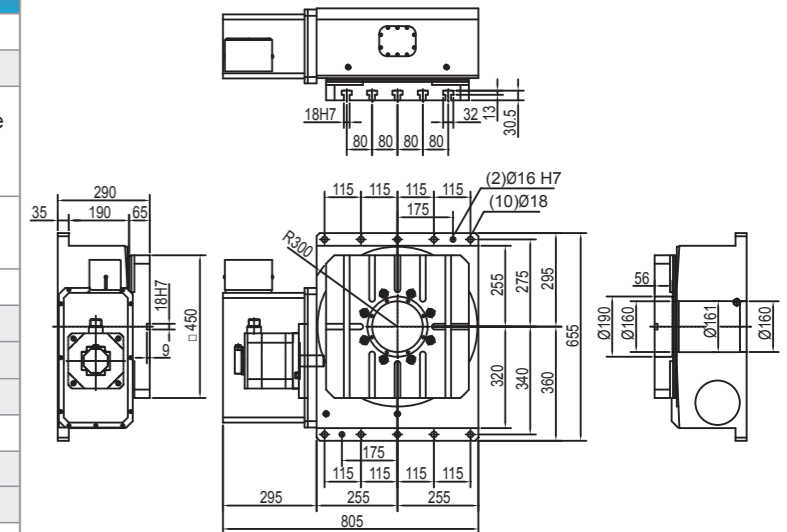
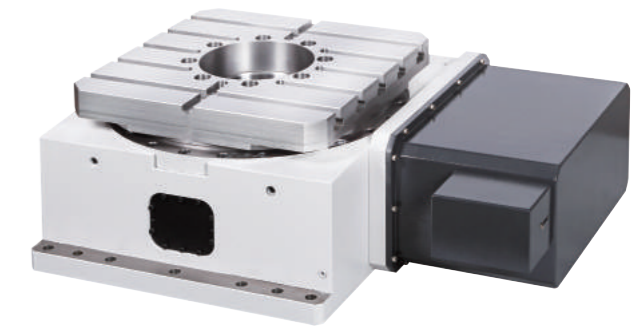

HRD650

Item	Unit	Specification	
Table diameter	mm	□ 650	
T-slot on table	mm	18H7	
Servo motor (Option)	FANUC	α iF22	Motor interface □ 176
		β is22	
	Mitsubishi	HF-354S	□ 192
		Siemens	
Heidenhain	QSY190C		
Total reduction ratio		120	
Maximum rpm	rpm	16.6(2000rpm)	
Index accuracy mini.	deg	0.001°	
Allowable load	kg	1200kg	
Clamp power source		Hydraulic	
Clamp pressure	kg / cm ²	20	
Clamp torque	kg-m	700	
Index accuracy	sec	13	
Repetition accuracy	sec	4	

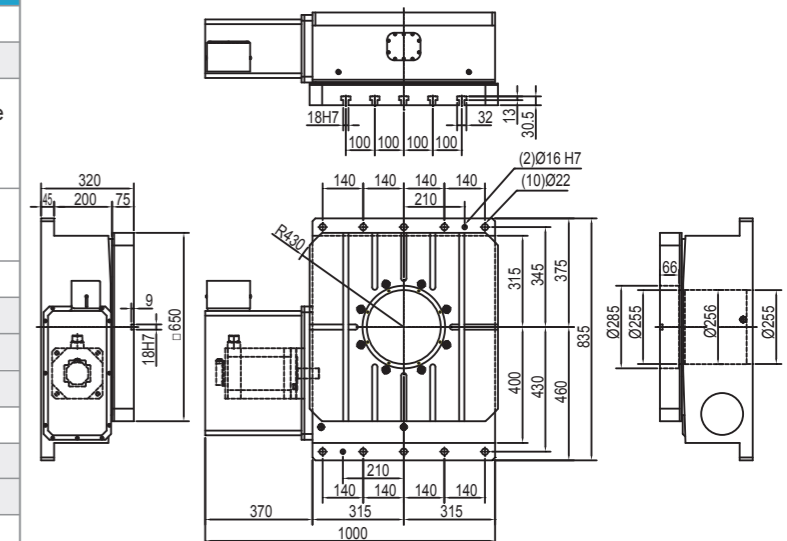

Faceplate Tailstock CR Series



▲ Faceplate Tailstock 185



▲ Faceplate Tailstock 160



▲ Faceplate Tailstock 135

CR series tailstock with different center heights and are able to be matched all kinds of rotary table. To assemble on fourth axis RD series and Fixtures to be perfect performance and effective working time and cost savings.

Type	Size/Center height
CR170 P/H	135mm
CR200 P/H	160mm
CR250 P/H	185mm
CR320 P/H	210mm

CR170

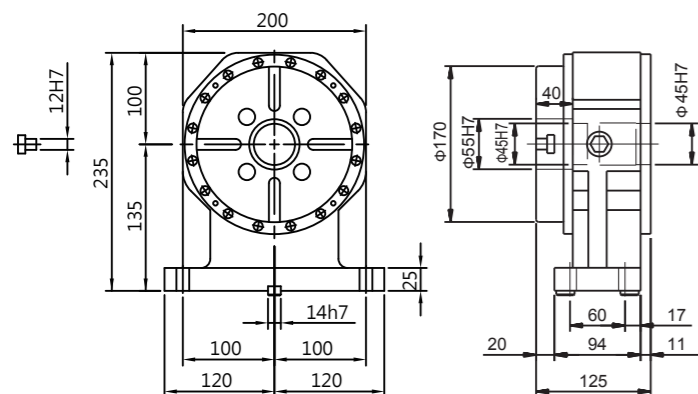

CR250

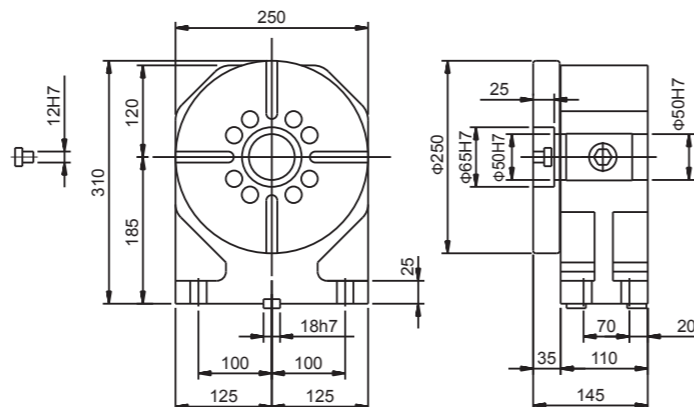

CR200

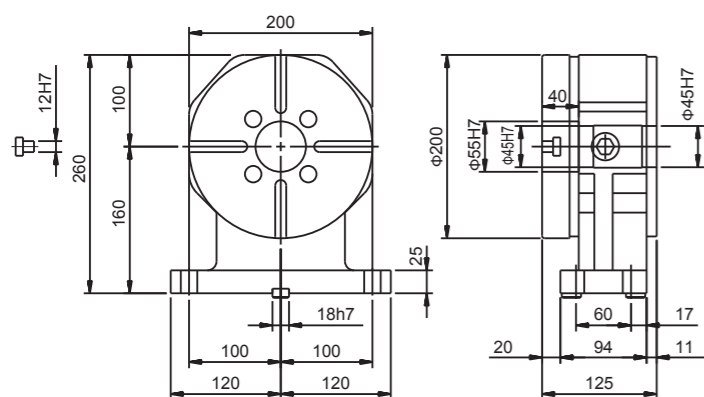

CR320

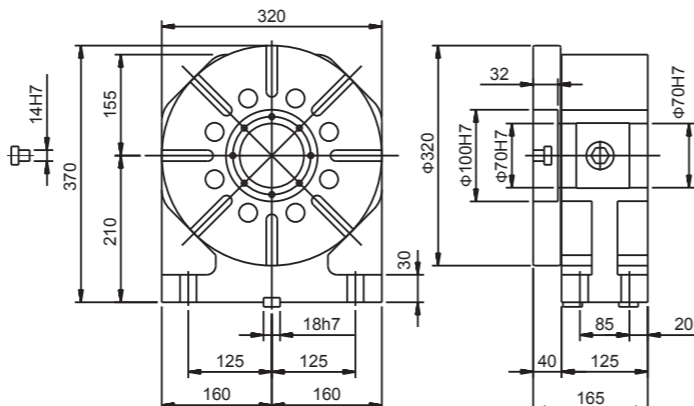

Manual Tailstock MT Series

MT135

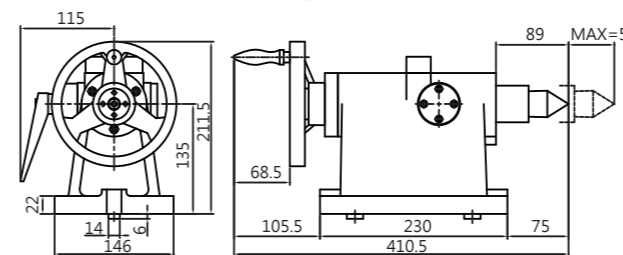

MT160

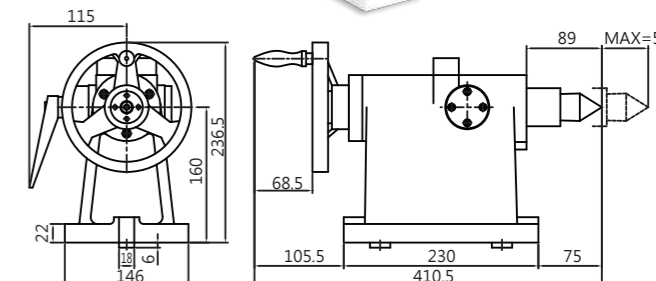

MT185

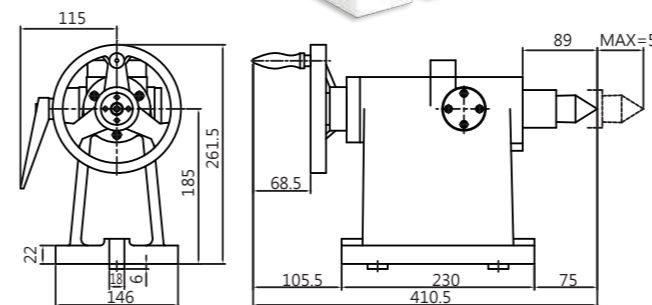

MT210

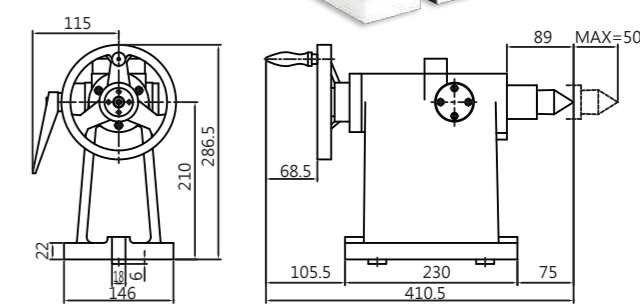

▲ Thimble type automatic tailstock (Pneumatic or Hydraulic)



▲ Pneumatic/hydraulic converter (8 times)
· Air pressure source 6kg/cm²
· Solenoid valve DC24V or AC110 / 220V

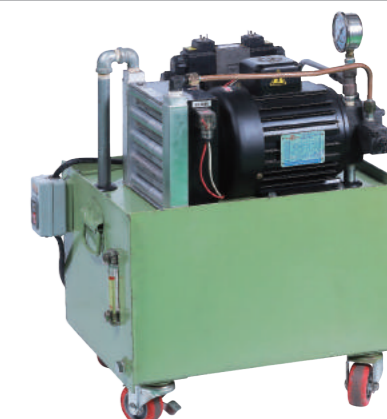

▲ Hydraulic device
· 1HP x 4P, 12 liter / min, 40L
· 2HP x 4P, 30 liter / min, 70L



Motor Type specification

Machine Specification	Machine Table Specification	Brand	Model		
	Machine Controller	<input type="checkbox"/> FANUC <input type="checkbox"/> Mitsubishi <input type="checkbox"/> Siemens <input type="checkbox"/> Heidenhain <input type="checkbox"/> Others _____			
	Driver and cables	<input type="checkbox"/> None <input type="checkbox"/> Cables only <input type="checkbox"/> Driver and cables			
Machine Table	T-slot width(A)	<input type="checkbox"/> 14mm <input type="checkbox"/> 16mm <input type="checkbox"/> 18mm <input type="checkbox"/> 22mm (Fig. II)			
	T-slot pitch size (B)	<input type="checkbox"/> 100mm <input type="checkbox"/> 150mm <input type="checkbox"/> Others _____ (Fig. II)			
	T-slot amount on table	<input type="checkbox"/> 3 <input type="checkbox"/> 4 <input type="checkbox"/> 5 <input type="checkbox"/> 6 <input type="checkbox"/> Others _____ Provide machine table dimension			
NC Rotary Table (4 axis)	Rotary table model number	RD80 RDE170 (no brake) <input type="checkbox"/> RD170 <input type="checkbox"/> RDS200 <input type="checkbox"/> RDS250 <input type="checkbox"/> RD200 <input type="checkbox"/> RD250 <input type="checkbox"/> Pneumatic brake <input type="checkbox"/> Hydraulic brake <input type="checkbox"/> RD320 <input type="checkbox"/> RD400 (Hydraulic brake)			
	Rotary table model number	<input type="checkbox"/> ACU150 <input type="checkbox"/> ACU200 <input type="checkbox"/> Pneumatic brake <input type="checkbox"/> AC320 <input type="checkbox"/> AC400 <input type="checkbox"/> AC650 <input type="checkbox"/> Pneumatic brake <input type="checkbox"/> Hydraulic brake (cradle 5-axis rotary table)			
NC Rotary Table (5 axes)	Clamping type	<input type="checkbox"/> Pneumatic <input type="checkbox"/> Hydraulic			
	Solenoid valve pneumatic lock	<input type="checkbox"/> AC110V <input type="checkbox"/> AC220V <input type="checkbox"/> DC24V			
	Outlet way of power/signal wires (P58)	<input type="checkbox"/> Military standard connector (Japan system) <input type="checkbox"/> Defensive device on tilt axle (standard) <input type="checkbox"/> Others _____			
	Mitsubishi system connecting	<input type="checkbox"/> 17PIN <input type="checkbox"/> 19PIN			
	Limit angle and switch type	<input type="checkbox"/> Standard (according to catalog spec) <input type="checkbox"/> Others _____ <input type="checkbox"/> 2-line NC (standard) <input type="checkbox"/> Others _____			
FANUC	α iF2/5000	α iF4/5000	α iF8/3000	α iF12/4000	α iF22/3000
	(α iS2/5000)	(α iS4/5000)	(α iS8/4000)	(α iS12/4000)	(α iS22/4000)
Mitsubishi	HF75T	HF54T	HF104T	HF204S	HF354S
Yaskawa	SGMPS-04	SGMGV-05	SGMGV-09	SGMGV-20	SGMGV-30
Siemens	1FK7042	1FK7060	1FK7063	1FK7083	1FK7101
Heidenhain	QSY96A	QSY116C	QSY116E	QSY155B	QSY155D
Tailstock (special attachment)	Changeable thimble manual tailstock (MT)	<input type="checkbox"/> MT-135 <input type="checkbox"/> MT-160 <input type="checkbox"/> MT-185 <input type="checkbox"/> MT-210			
	Faceplate braking tailstock	<input type="checkbox"/> CR-135 <input type="checkbox"/> CR-160 <input type="checkbox"/> CR-185 <input type="checkbox"/> CR-210 <input type="checkbox"/> Pneumatic brake <input type="checkbox"/> Hydraulic brake			
Attachment OK					

Motor junction box
 Upper Side Back

Mounting location of 5-axis NC rotary table and machine
 (Fig. 1) (Fig. 2)
 1.5-axis NC rotary table is installed by parallel to Y-axis. 2.5-axis NC rotary table is installed by parallel to X-axis



Accuracy inspection diagram

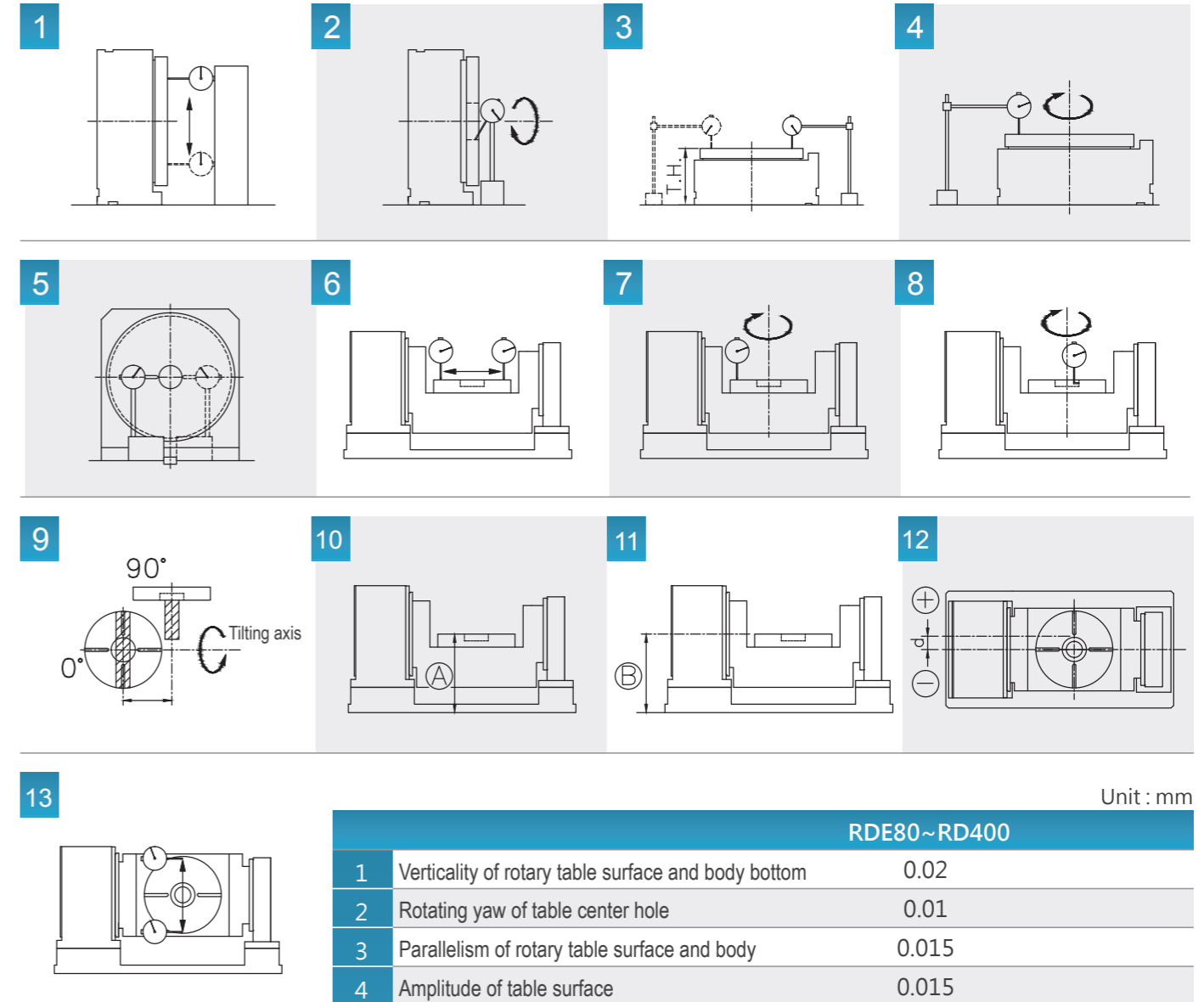

Unit : mm

RDE80~RD400			
1	Verticality of rotary table surface and body bottom	0.02	
2	Rotating yaw of table center hole	0.01	
3	Parallelism of rotary table surface and body	0.015	
4	Amplitude of table surface	0.015	
5	Parallelism of table center and datum block	0.02	
5	Sides tolerance of table center and datum block	0.02	
AC(5-axis model)			
6	Verticality of table surface and bottom	0.01	
7	Plate Amplitude of table in rotating	0.02	
8	Concentricity of table internal hole in rotating	0.01	
9	Change location of tilting axis (0° ~ +/-90°) in rotating	0.02	
10	Height of table and datum block	A±0.5	
11	Height of tilting axis center & rotating axis center	B±0.5	
12	Yaw distance of tilting axis center & rotating axis center	0.02	
13	Perpendicular tolerance of table when tilting axis 90° (test from our plant)	0.02	
14	Index accuracy	Rotating axis	see specification table
		Tilting axis	see specification table
	Repetition accuracy	Rotating axis	see specification table
		Tilting axis	see specification table